

Diffusion of Innovation in Social Networking Sites among University Students

Olusegun Folorunso

*Department of Computer Science,
University of Agriculture Abeokuta, Ogun State, Nigeria.*

folorunsolusegun@yahoo.com

Rebecca O. Vincent

*Department of Computer Science,
University of Agriculture Abeokuta, Ogun State, Nigeria.*

Rebecca.vincent@gmail.com

Adebayo Felix Adekoya

*Department of Computer Science,
University of Agriculture Abeokuta, Ogun State, Nigeria.*

lanlenge@gmail.com

Adewale Opeoluwa Ogunde

*Department of Mathematical Sciences,
Redeemer's University (RUN), Redemption City, Mowe,
Ogun State, Nigeria.*

adewaleogunde@yahoo.com

Abstract

Diffusion of Innovations (DOI) is a theory of how, why, and at what rate new ideas and technology spread through cultures. This study tested the attributes of DOI empirically, using Social networking sites (SNS) as the target innovation. The study was conducted among students of the University of Agriculture, Abeokuta in Nigeria. The population comprised of people already connected to one social networking site or the other. Data collection instrument was a structured questionnaire administered to 120 respondents of which 102 were returned giving 85% return rate. Principal Factor Analysis and Multiple Regression were the analytical techniques used. Demographic characteristics of the respondents revealed that most of them were students and youths. From the factor analysis performed, it was revealed the constructs: relative advantage, complexity, and observability of SNS do not positively affect the attitude towards using the technology while the compatibility and trialability of SNS does positively affect the attitude towards using the technology. The study concluded that the attitude of university students towards SNS does positively affect the intention to use the technology.

Keywords: Diffusion of Innovation, Social networking sites, Adoption, Intention.

1.0 INTRODUCTION

Social networking sites (SNS) such as MySpace, Facebook, Cyworld, Bebo BlackPlanet, Dodgeball, and YouTube have attracted millions of users, many of whom have integrated these sites into their daily practices. A social network service focuses on building online communities of people who share interests and/or activities (Dwyer et al., 2007). The websites allow users to build on-line profiles, share information, pictures, blog entries, music clips, etc. After joining a social networking site, users are prompted to identify others in the system with which they have a relationship. The label for these relationships differs depending on the site-popular terms include "Friends," "Contacts," and "Fans." Most SNS require bi-directional confirmation for Friendship.

Diffusion is defined as the process by which an innovation is adopted and gains acceptance by members of a certain community. A number of factors interact to influence the diffusion of an innovation (Lee, 2004). The four major factors that influence the diffusion process are the innovation itself, how information about the innovation is communicated, time, and the nature of the social system into which the innovation is being introduced (Rogers, 1995). The Diffusion of Innovation Theory (DOI) is used in this study to examine the factors influencing adoption of social networking sites innovation. The theory proposed five beliefs or constructs that influence the adoption of any innovation (Davis et al., 1989). These are relative advantage, complexity, compatibility, trialability, and observability. The essence of the use of these constructs is to empirically test part of DOI's attributes with a view to exploring factors that brought about the adoption of the innovation of social networking sites (Penning and Harianto, 2007).

Therefore in this paper, the constructs that could affect the adoption of these networking sites were studied. The theory of diffusion of innovation will therefore be extended to social networking among University students to determine the extent of use and acceptance with a view to knowing what could be done to prevent or allow the inhibition surrounding its use. Thus, it could be reasoned that the benefits of these sites would accrue to adopters when barriers to their diffusion and adoption are identified. The DOI theory was used in an attempt to model the adoption of social networking sites, so that the progression of its use could be anticipated and fully catered for.

Hence, the study analyses the adoption of social networking sites among the University Students and their intention of using it with selected constructs such as relative advantage, complexity, compatibility, trialability, and observability.

2.0 RELATED WORKS

The social networking sites associated to a particular region differs, hence the reason for joining these sites differs from one person to another. Although, social networking sites have been in existence for quite a while, its adoption in Africa has recently increased. Social networking sites are built for users to interact for different purposes like business, general chatting, meeting with friends and colleagues, etc. It is also helpful in politics, dating, with the interest of getting numerous advantages with the people they meet. Recently, the use of network sites has increased overtime in Africa with the improvement in technology and the use of mobile phone to surf the web and statistic have shown that 90% of people on the internet at one point in time or the other are visiting social network sites (Boyd and Ellison, 2007).

In Africa, social networking sites is becoming widely spread than it has ever been before and it tends to be majorly accepted by the youths. Yet the widespread adoption by users of these sites is not clear, as it appears that people's perception of this technology is diverse, which in turn affects their decision to actually trust these sites or not. Moral panic is a major problem to trusting the innovation (Adler and Kwon, 2002; Bargh and Mckenne, 2004). These one-directional ties are sometimes labelled as "Fans" or "Followers," but many sites call them Friends as well. The term "Friends" can be misleading, because the connection does not necessarily mean friendship in the

everyday vernacular sense, and the reasons people connect are varied (Boyd, 2004). Unsafe disclosure of information to both known and unfamiliar population, reputation of individuals, cyberbullying, addiction, risky behavior and contacting dangerous communities are issues affecting trust of SNS, though, it is adopted. The primary reason for its adoption may be unknown. There is obviously, a need to investigate the issue of adoption of social networking sites in this context, because the diffusion of the innovation of these sites can be specifically perceived by the users through their attitudes and actions.

Many researchers have studied the Innovation diffusion theory, but none has applied it to Social networking sites. Among them are Lee (2004), who applied Everett Rogers' innovation-diffusion model to analyze nurses' perceptions toward using a computerized care plan system. Twelve nurses from three respiratory intensive care units in Taiwan voluntarily participated in a one-on-one, in-depth interview. Data were analyzed by constant comparative analysis. The content that emerged was compared with the model's five innovation characteristics (relative advantage, compatibility, complexity, trialability, and observability), as perceived by new users. Results indicated that Rogers' model can accurately describe nurses' behavior during the process of adopting workplace innovations (Shao, 2007). Also, related issues that emerged deserve further attention to help nurses make the best use of technology. (Lee, 2004). The application of health information technology to improve healthcare efficiency and quality is an increasingly critical task for all healthcare organizations due to rapid improvements in IT and growing concerns with regard to patient's safety.

Oladokun and Igbiniedum, (2009) presented a work on the adoption of Automatic Teller Machines (ATM) in Nigeria: An Application of the Theory of Diffusion of Innovation. The study tested the attributes of the theory of diffusion of innovation empirically, using Automatic Teller Machines (ATMs) as the target innovation. The study was situated in Jos, Plateau state, Nigeria. The population comprised banks customers in Jos who used ATMs. The sampling frame technique was applied, and 14 banks that had deployed ATMs were selected. Cluster sampling was employed to select respondents for the study. Data collection instrument was a structured questionnaire administered to 600 respondents of which 428 were returned giving 71.3% return rate. Principal Factor Analysis, and Multiple Regression were the analytical techniques used. The demographic characteristics of the respondents revealed that most of them were students and youths. From the factor analysis, it was revealed that the respondents believed in their safety in using ATM; that ATMs were quite easy to use and fit in with their way of life; that what they observed about ATMs convinced them to use it and that ATM was tried out before they use it.

Zhenghao et al, 2009 worked on the 3G Mobile Phone Usage in China: Viewpoint from Innovation Diffusion Theory and Technology Acceptance Model. The paper analyzed the reasons behind Innovation Diffusion Theory (IDT) and Technology Acceptance Model (TAM) perspectives. Some suggestions were also given to 3G business operators and researchers.

Others who researched on SNS include Boyd and Ellison (2007), who described features of SNS and propose a comprehensive definition for it. They presented a perspective on the history of social network sites, discussing key changes and developments. Ellison et al (2007) also examined the relationship between the use of Facebook, a popular online social networking site, and the formation and maintenance of social capital. In addition to assessing bonding and bridging social capital, they explored a dimension of social capital that assesses one's ability to stay connected with members of a previously inhabited community, which was called - maintained social capital. Regression analyses was conducted on results from a survey of undergraduate students (N=286), which suggested a strong association between use of Facebook and the three types of social capitals, with the strongest relationship being the bridging social capital. In addition, Facebook usage was found to interact with measures of psychological well-being, suggesting that it might provide greater benefits for users experiencing low self-esteem and low life satisfaction. Their results demonstrated a robust connection between Facebook usage and indicators of social capital, especially of the bridging type that Internet use alone did not predict social capital accumulation, but intensive use of Facebook did.

Dwyer et al, 2007 analysed an online survey of two popular social networking sites, Facebook and MySpace, compared perceptions of trust and privacy concerns, along with willingness to share information and develop new relationships. Members of both sites reported similar levels of privacy concern. Facebook members expressed significantly greater trust in both Facebook and its members, and were more willing to share identifying information. Even so, MySpace members reported significantly more experience using the site to meet new people. These results suggested that in online interaction, trust is not as necessary as the building of new relationships, as it is in face to face encounters. They also showed that in an online site, the existence of trust and the willingness to share information do not automatically translate into new social interaction. This study demonstrated online relationships can develop in sites where perceived trust and privacy safeguards are weak.

3.0 RESEARCH MODEL

Figure 1 shows the research model. Relative advantage indicates the usefulness of an innovation; compatibility is the degree to which an innovation is perceived as consistent with existing values, past experiences, and the needs of the potential adopter; complexity is the degree to which an innovation is perceived as relatively difficult to understand and use; trialability is trying out or testing an innovation so that it makes meaning to the adopter; and observability is the degree to which the results of an innovation are visible to others.

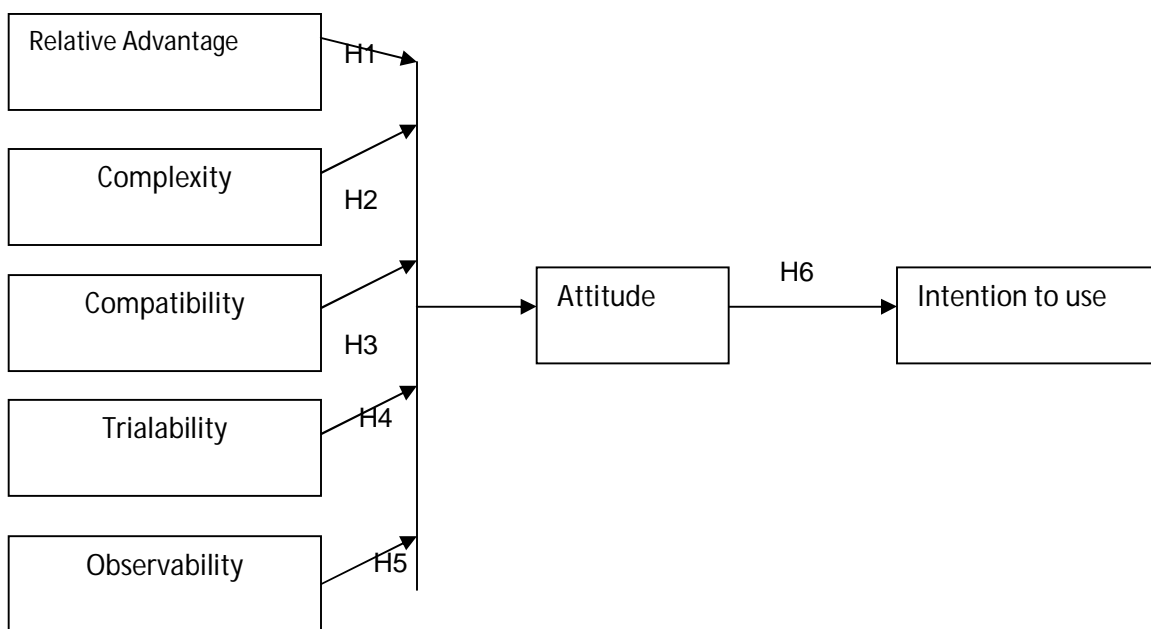

FIGURE 1: Research model

The research model adopted in this study depicts what should occur given the constructs that was proposed by Rogers (1995) concerning the adoption of a technology. These constructs ought to affect the intention to use a particular innovation which in this case is Social Networking sites. Thus, the model indicates that the five constructs: relative advantage, complexity, compatibility, trialability and observability of using social network sites would affect the intention of the adopter to use these sites. The hypotheses proposed for this study are as follows:

Ho₁: The relative advantage of using social networking sites does not positively affect users' attitude towards using the technology.

Ho₂: The complexity of the use of social networking sites does not positively affect users' attitude towards using the technology.

Ho₃: The compatibility of social networking sites with the adopter's values does not positively affect users' attitude towards using the technology.

Ho₄: The trialability of social networking sites does not positively affect users' attitude toward using the technology.

Ho₅: The observability of social networking sites does not positively affect users' attitude towards using the technology.

Ho₆: The attitude towards social networking sites does not positively affect users' intention to use the technology.

3.1 Sample and Procedure

The six attributes measured users' perception regarding the advantage, trust and security of SNS to the University students and most especially the rate of adoption of the innovation. Relative advantage, complexity, compatibility, trialability, observability and trust were measured to access individual perceptions and adoption of effectiveness of the innovation. The survey subjects were mainly students in Nigerian Universities. A close-ended questionnaire was designed to collect relevant data on the relative advantage of using social networking sites, whether any complications had been encountered from the use of these sites, and on the suitability of using these sites with the belief system, moral and ethical values of the respondents. Information on how the experiences of the respondents with the use of social networking sites have affected their intentions regarding the continuous use the SNS technology. One hundred and twenty (120) questionnaires were administered to students in the University of Agriculture, Abeokuta in Nigeria, out of which a hundred and two were returned and eighteen were not returned. The percentage of the useable copies of the questionnaire was 85 percent. The profile of the respondent is shown in Table 1.

Demographic Information of the Sample (n=102)		
Variables	Frequency	Percent (%)
Gender		
Male	58	56.9
Female	44	43.1
Age		
Under 18	0	
19-29	102	100
Period of use of Social network sites		
Less than a month	2	2.0
1-6months	16	15.7
6months to a year	28	27.5
1-2years	34	36.3
2-3years	12	11.8
Over 3years	7	8.67
How many friends in total do you have in all of your networking sites?		
1-20	7	6.9
21-60	18	17.6
61-100	38	37.3
100+	39	38.2
Do you believe visiting these sites is a waste of time?		
Yes	5	4.9
Maybe	29	28.4
No	68	66.7

TABLE 1: Demographic Information of the Sample (n=102)

As shown in Table 1, there were more males than females at 56.9% to 43.1%. All of the respondents were between the ages of 19-29 years.

3.2 Data Analysis and Results

The data collected were analysed using Cronbach’s alpha which was to determine the internal consistency and reliability of the individual and multiple scales. Cronbach’s alpha was used in this study because every item in the questionnaire measured an underlying construct. Cluster sampling was adopted; this involved the division of the population into clusters or groups and drawing samples from the clusters. A cluster in this study was represented by the number of users who are parts of one social networking site or the other. The validity of the measures was verified by observing the correlations between the items on the various scales. All pre-existing constructs used in the diffusion theory met the criteria of validity and reliability except trust which is a newly introduced construct.

Construct	Cronbach’s Alpha	No of items that make up the constructs
Relative advantage	0.415	4
Complexity	0.359	3
Compatibility	0.754	3
Observability	0.320	3
Triability	0.562	3

TABLE 2: Reliability Test

Table 2 showed the Cronbach’s alpha that was computed for the items that made up each construct used in this study. The alpha values for the 5 constructs (from 0.32 and 0.75) indicated that the items that formed them do not have reasonable internal consistency reliability. The items which were deleted had alpha values that were either lesser than 0.3 or higher than 0.75. Items lower than 0.3 might affect the consistency of the results of further analysis. Items with alpha values over 0.73 were probably repetitious or added up to be more than what was required for the construct. The scores used for the constructs in this study were standardized using SPSS package for the regression analysis.

Tables 3 and 4 presents the result from the multiple regression carried out using the five constructs: Relative Advantages, Complexity, Compatibility, Observability, Trialability as the independent variables and Attitude as the dependent variable. This is done to determine the best linear combination of the constructs for predicting Attitude.

Model	Sum of Squares	Df	Mean Square	F	Sig.
Regression	2.917	5	.583	2.338	
Residual	23.955	96	.250		0.48
Total	26.873	101			

TABLE 3: ANOVA for the Constructs

Model	Unstandardized Coefficients		Standardized Coefficients	t	Sig.	Collinearity Statistics	
	B	Std. Error	Beta			Tolerance	VIF
1 (Constant)	2.276	.533		4.269	.000		
Relative Advantage	-.028	.052	-.054	-.548	.585	.958	1.043
Trialability	-.112	.050	-.217	-2.235	.028	.987	1.013
Compatibility	.207	.092	.221	2.242	.027	.956	1.046
Observability	.112	.080	.142	1.407	.163	.908	1.102
Complexity	-.111	.080	-.140	-1.396	.166	.918	1.090

TABLE 4: Coefficient of the Constructs

Table 4 presents the ANOVA report on the general significance of the model. As p is less than 0.05, the model is significant. Thus the combination of the variables significantly predicts the dependent variable. Table 5 shows the beta coefficients for each variable. The t and p values present the significance of each variable and their impact on the dependent variable (attitude). From table 4 only trialability and compatibility had significant impact on respondent's attitude, with compatibility having the highest impact on attitude. The multiple regression equation for this analysis is given as

$$\text{Attitude} = 2.276 - 0.28 (\text{Relative Advantage}) - 0.112 (\text{Trialability}) + 0.207 (\text{Compatibility}) + 0.112 (\text{Observability}) - 0.111 (\text{Complexity}) \dots(1)$$

Tables 5, 6 and 7 present the result from the multiple regression carried out using Attitude as the independent variable and Intention as the dependent variable. This was done to determine the best linear combination of Attitude for the prediction of Intention

Model	R	R Square	Adjusted R Square	Std. Error of the Estimate
1	.050 ^a	.003	-.007	.720

Predictors: (Constant), Attitude
 Dependent variable: Intent

TABLE 5: Model Summary for attitude and intent

Model		Sum of Squares	Df	Mean Square	F	Sig.
1	Regression	.132	1	.132	.254	.615 ^a
	Residual	51.829	100	.518		
	Total	51.961	101			

Predictors: (Constant), Attitude
 Dependent Variable: Intent

TABLE 6: ANOVA for attitude and intent

Model		Unstandardized Coefficients		Standardized Coefficients	T	Sig.
		B	Std. Error	Beta		
1	(Constant)	1.248	.149		8.389	.000
	Attitude	.048	.094	.050	.504	.615

Dependent Variable: Intent

TABLE 7: Coefficients for attitude and intent

From table 6, it can be seen that R square value is very low; hence the variance in the model cannot be predicted from the independent variable, attitude. Table 7 gives the ANOVA test on the general significance of the model, as p is greater than 0.05, the model is not significant. Thus, attitude of the respondents cannot significantly predict the dependent variable, Intent. Table 7

shows the coefficients of attitude, and from the table it can be seen that attitude has a very low impact on Intention, the small t value and corresponding large p-value shows this. The regression equation for this analysis consequently is:
 $Intention = 1.248 + 0.048(Attitude)$.

Test of Hypotheses

Table 8 shows the result of the hypothesis tested against p values that were obtained from the above results.

Variable	Beta	P
Relative Advantage	-0.54	P<0.05
Complexity	-2.17	P<0.05
Compatibility	2.21	P<0.05
Observability	1.42	P<0.05
Triability	-1.40	P<0.05

TABLE 8: Result of beta and p

he decisions in respect of the hypotheses are

Ho₁: The relative advantage of using social networking sites does not positively affect users' attitude towards using the technology. Accepted

Ho₂: The complexity of the use of social networking sites does not positively affect users' attitude towards using the technology. Accepted

Ho₃: The compatibility of social networking sites with the adopter's values does not positively affect users' attitude towards using the technology. Rejected

Ho₄: The trialability of social networking sites does not positively affect users' attitude toward using the technology. Rejected

Ho₅: The observability of social networking sites does not positively affect users' attitude towards using the technology. Accepted

Ho₆: The attitude towards social networking sites does not positively affect users' intention to use the technology. Rejected

This is depicted by figure 2 below.

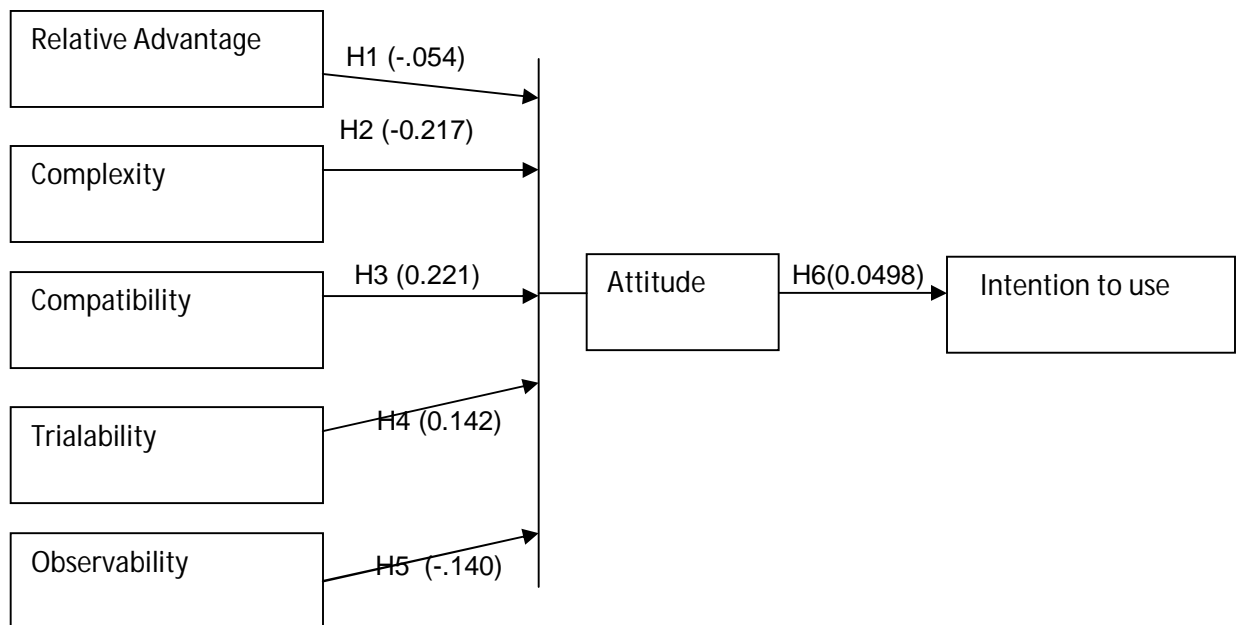

Figure 2: Findings of the DOI constructs

4.0 DISCUSSION OF FINDINGS

Relative Advantage ($\beta = -0.54$, $p < 0.05$) does not have significant positive effect on the attitude towards using social networking sites. From the responses, the advantages of using these sites do not make them prefer social network sites use to the previous one used. Some of these advantages include speed, efficiency, availability, ease of use, faith in the security of their personal information. The contribution of the Complexity construct ($\beta = 2.21$, $p < 0.05$) was not also significant to the model and hence not supported in this study. The complexity of a technology affects how well that technology diffuses in a social network system because if the technology is easy to use, more people are likely to adopt its use. Findings from this study suggested that social networking sites were not quite easy to use and are not more likely to be more widely adopted. The Compatibility construct ($\beta = -1.40$, $p < 0.05$) was found to positively contribute to the DOI model. This suggested that the compatibility of usage social networking sites to the lifestyle of the respondents was important. The use social networking sites now belong firmly to the modern way of doing things.

The Observability construct ($\beta = 1.42$, $p < 0.05$) also have impact on the attitude towards the use of these sites. It also showed that people paid more attention to it than might have previously been the case. The Observability construct was not simply about watching others using the technology, but (as the results from the factor analysis revealed) involved perception and discernment, usually brought on by the influence of others. Of the five constructs, Trialability ($\beta = -0.217$, $p < 0.05$) had the highest impact on the attitude towards using social networking sites, it was positively significant. The results implied that the respondents have attempted to try SNSs before adopting its use. This finding suggested that people just decide to adopt and use social networking sites after testing it. This could be because of their already perceived notions as to the advantages of using these sites. Since the construct is very significant in this study, it meant that potential adopters of these sites may well benefit from trial demonstrations as an introduction to using the technology. This would help eliminate uncertainty about social networking sites, improve confidence in its use and make its diffusion more widespread.

The Attitude ($\beta = 0.050$, $p < 0.05$) towards SNSs positively and significantly affected the Intention to use the technology. The low impact of Attitude on Intention to use social network sites expressed the importance of how Attitude could affect the Intention to use social networking sites. A positive attitude meant that a potential adopter or a past user of social sites would have the Intention to use it in future and vice versa. The contribution of Attitude to Intention in the DOI model has been in line with the findings of other studies such as those of Davis et al (1989).

The findings showed that attitudinal dispositions do not have significant influence use of social network sites. All the five attitudinal constructs have strong influences on adoption and intention to use social networking sites. Complexity also does not have significant relationship with intention to use it. Analysis for compatibility revealed that the use of social networking sites was compatible with the lifestyle of the respondents. The study also revealed that the use of social networking sites is widespread and a current practice today because of its usefulness but because of its compatibility with users' previous values. The implications of observability construct showed that the observations made by the respondents effectively convinced them not to use SNS. Influence was apparently a factor for using social networks, probably because the students quickly get influenced by their colleagues. Another construct that influenced attitude and trust of SNS supported in this study is trialability. Potential social networking sites adopters will be more inclined to use it if they can try it out first.

These findings have shown what the Diffusion of Innovation model in the diffusion of Social networking sites. It is therefore noteworthy for builders of these sites to examine the attributes of the model to see how they could improve on the use of these sites.

6.0 Conclusions

This study analysed the issues surrounding the adoption of social networking sites (SNS) using diffusion of innovation theory (DOI) to test its adoption among University students. Five major constructs: Relative Advantage, Complexity, Compatibility, Observability and Trialability were used to test the impact on the attitude and trust regarding SNS and to determine how attitude would impact on the intention to use it. From the results, it could be said that the relative advantage of using SNS; how hard it was to use; how compatible it were with the lifestyle of the users; how much has been registered about SNS by the users; and whether social networking sites could be tested before consistent use, were issues that influence users' attitude towards intention it use. The Attitude of a user would later affect his/her intention to use the site. Since trialability and compatibility had the greatest impact on attitude, it follows that the social networking sites follow the student's lifestyle and would assist in consummating greater diffusion of social networking sites in among students and opportunity for adopters to experiment with the system before making any long-term commitment. Future studies could consider the inclusion of specifics on innovation diffusion with respect to geographical location and the cultural considerations of another area. The diffusion of social networking sites in Nigeria could also be studied from the perspective of non-users, to determine why they persist in non-usage of this technology.

References

- P. Adler, S. Kwon. "Social capital: Prospects for a new concept". *Academy of Management Review*, 27 (1), 17-40, 2002
- J. Bargh, K. McKenna. "The Internet and social life". *Annual Review of Psychology*, 55 (1), 573-590, 2004
- D. Boyd. "Friendster and publicly articulated social networks". In *Proceedings of ACM Conference on Human Factors in Computing Systems* New York: ACM Press, 2004

D.M. Boyd and N. B. Ellison. "Social network sites: Definition, history, and scholarship". Journal of Computer-Mediated Communication. 13(1), article 11, 2007.

F. D. Davis, R. P. Bagozzi and Warshaw, P. R. "User acceptance of computer technology: A comparison of two theoretical models". Management Science, 35(8), 982-1003, 1989

C. Dwyer, S. R. Hiltz, and Passerini, K. "Trust and privacy concern within social networking sites: A comparison of Facebook and MySpace". In Proceedings of AMCIS 2007, Keystone, Colorado, USA, 2007. Retrieved September 21, 2007 from <http://csis.pace.edu/~dwyer/research/DwyerAMCIS2007.pdf>

T. Lee. "Nurses adoption of technology: Application of Rogers innovation-diffusion model", Applied Nursing Research, 17(4), Pages 231-238, 2004

W. M. Olatokun, L. J. Igbinedion.. "The Adoption of Automatic Teller Machines in Nigeria: An Application of the Theory of Diffusion of Innovation", Issues in Informing Science and Information Technology, Vol. (6)374-392, 2009

J. M. Penning, F. Harianto. "The diffusion of technological innovation in the commercial banking industry". Strategic Management Journal, 13(1), 29-46, 2007

E. M. Rogers. "Diffusion of innovations", 4th Edition, The Free Press: New York. 1995

Z. Zhenghao, M. T. Liu, and M. P. Chuan. "3G Mobile Phone Usage in China: Viewpoint from Innovation Diffusion Theory and Technology Acceptance Model". In Proceedings of the 2009 International Conference on Networking and Digital Society (ICND), Guiyang, China, 2009