

INTERNATIONAL JOURNAL OF  
**COMPUTER NETWORKS (IJCN)**

ISSN : 1985-4129

Publication Frequency: 6 Issues / Year



CSC PUBLISHERS  
<http://www.cscjournals.org>

# **INTERNATIONAL JOURNAL OF COMPUTER NETWORKS (IJCN)**

**VOLUME 6, ISSUE 1, 2014**

**EDITED BY  
DR. NABEEL TAHIR**

ISSN (Online): 1985-4129

International Journal of Computer Networks (IJCN) is published both in traditional paper form and in Internet. This journal is published at the website <http://www.cscjournals.org>, maintained by Computer Science Journals (CSC Journals), Malaysia.

IJCN Journal is a part of CSC Publishers

Computer Science Journals

<http://www.cscjournals.org>

# **INTERNATIONAL JOURNAL OF COMPUTER NETWORKS (IJCN)**

Book: Volume 6, Issue 1, March 2014

Publishing Date: 19-03-2014

ISSN (Online): 1985-4129

This work is subjected to copyright. All rights are reserved whether the whole or part of the material is concerned, specifically the rights of translation, reprinting, re-use of illustrations, recitation, broadcasting, reproduction on microfilms or in any other way, and storage in data banks. Duplication of this publication of parts thereof is permitted only under the provision of the copyright law 1965, in its current version, and permission of use must always be obtained from CSC Publishers.

IJCN Journal is a part of CSC Publishers

<http://www.cscjournals.org>

© IJCN Journal

Published in Malaysia

Typesetting: Camera-ready by author, data conversion by CSC Publishing Services – CSC Journals, Malaysia

**CSC Publishers, 2014**

## EDITORIAL PREFACE

The International Journal of Computer Networks (IJCN) is an effective medium to interchange high quality theoretical and applied research in the field of computer networks from theoretical research to application development. This is the *First* Issue of Volume *Six* of IJCN. The Journal is published bi-monthly, with papers being peer reviewed to high international standards. IJCN emphasizes on efficient and effective image technologies, and provides a central for a deeper understanding in the discipline by encouraging the quantitative comparison and performance evaluation of the emerging components of computer networks. Some of the important topics are ad-hoc wireless networks, congestion and flow control, cooperative networks, delay tolerant networks, mobile satellite networks, multicast and broadcast networks, multimedia networks, network architectures and protocols etc.

The initial efforts helped to shape the editorial policy and to sharpen the focus of the journal. Started with Volume 6, 2014, IJCN aims to appear with more focused issues. Besides normal publications, IJCN intend to organized special issues on more focused topics. Each special issue will have a designated editor (editors) – either member of the editorial board or another recognized specialist in the respective field.

IJCN give an opportunity to scientists, researchers, engineers and vendors to share the ideas, identify problems, investigate relevant issues, share common interests, explore new approaches, and initiate possible collaborative research and system development. This journal is helpful for the researchers and R&D engineers, scientists all those persons who are involve in computer networks in any shape.

Highly professional scholars give their efforts, valuable time, expertise and motivation to IJCN as Editorial board members. All submissions are evaluated by the International Editorial Board. The International Editorial Board ensures that significant developments in computer networks from around the world are reflected in the IJCN publications.

IJCN editors understand that how much it is important for authors and researchers to have their work published with a minimum delay after submission of their papers. They also strongly believe that the direct communication between the editors and authors are important for the welfare, quality and wellbeing of the journal and its readers. Therefore, all activities from paper submission to paper publication are controlled through electronic systems that include electronic submission, editorial panel and review system that ensures rapid decision with least delays in the publication processes.

To build its international reputation, we are disseminating the publication information through Google Books, Google Scholar, Directory of Open Access Journals (DOAJ), Open J Gate, ScientificCommons, Docstoc and many more. Our International Editors are working on establishing ISI listing and a good impact factor for IJCN. We would like to remind you that the success of our journal depends directly on the number of quality articles submitted for review. Accordingly, we would like to request your participation by submitting quality manuscripts for review and encouraging your colleagues to submit quality manuscripts for review. One of the great benefits we can provide to our prospective authors is the mentoring nature of our review process. IJCN provides authors with high quality, helpful reviews that are shaped to assist authors in improving their manuscripts.

### **Editorial Board Members**

International Journal of Computer Networks (IJCN)

## **EDITORIAL BOARD**

### **EDITOR-in-CHIEF (EiC)**

**Dr. Min Song**

University of Toledo, Ohio (United States of America)

### **ASSOCIATE EDITORS (AEiCs)**

---

**Dr. Qun Li**

The College of William and Mary  
United States of America

**Dr. Sachin Shetty**

Tennessee State University  
United States of America

**Dr. Liran Ma**

Michigan Technological University  
United States of America

**Dr. Benyuan Liu**

University of Massachusetts Lowell  
United States of America

**Assistant Professor Tommaso Melodia**

University at Buffalo  
United States of America

### **EDITORIAL BOARD MEMBERS (EBMs)**

---

**Dr. Wei Cheng**

George Washington University  
United States of America

**Dr. Yu Cai**

Michigan Technological University  
United States of America

**Dr. Ravi Prakash Ramachandran**

Rowan University  
United States of America

**Dr. Bin Wu**

University of Waterloo  
Canada

**Dr. Jian Ren**

Michigan State University  
United States of America

**Dr. Guangming Song**  
Southeast University  
China

**Dr. Jiang Li**  
Howard University  
China

**Dr. Fang Liu**  
University of Texas at Pan American  
United States of America

**Dr. Enyue Lu**  
Salisbury University  
United States of America

**Dr. Chunsheng Xin**  
Norfolk State University  
United States of America

**Dr. Imad Jawhar**  
United Arab Emirates University  
United Arab Emirates

**Dr. Yong Cui**  
Tsinghua University  
China

**Dr. Zhong Zhou**  
University of Connecticut  
United States of America

**Associate Professor Cunqing Hua**  
Zhejiang University  
China

**Dr. Manish Wadhwa**  
South University  
United States of America

**Associate Professor Paulo de Figueiredo Pires**  
Federal University of Rio de Janeiro  
Brazil

**Associate Professor Vijay Devabhaktuni**  
University of Toledo  
United States of America

**Dr. Mukaddim Pathan**  
CSIRO-Commonwealth Scientific and Industrial Research Organization  
Australia

**Dr. Bo Yang**  
Shanghai Jiao Tong University  
China

**Assistant Professor Yi Gu**

University of Tennessee at Martin  
United States of America

**Assistant Professor Tarek Guesmi**

University of Nizwa  
Oman

**Dr Yan Sun**

Washington State University  
United States of America

**Associate Professor Flavia C. Delicato**

Federal University of Rio de Janeiro  
Brazil

**Dr. Rik Sarkar**

Free University of Berlin  
Germany

**Associate Professor Mohamed Younis**

University of Maryland, Baltimore County  
United States of America

**Dr. Jinhua Guo**

University of Michigan  
United States of America

**Associate Professor Habib M. Ammari**

University of Michigan Dearborn  
United States of America

## TABLE OF CONTENTS

Volume 6, Issue 1, March 2014

### Pages

- 1 - 14      SIP-Based Mobility Management for LTE-WiMAX-WLAN Interworking Using IMS  
Architecture  
*Reem A. Hamada, Hanaa S. Ali, M. I. Abdalla*



# SIP-Based Mobility Management for LTE-WiMAX-WLAN Interworking Using IMS Architecture

**Reem A. Hamada**

*Faculty of Engineering / Electronics and Communication Department  
Zagazig University  
Zagazig, 44519, Egypt*

*reemhamada@zu.edu.eg*

**Hanaa S. Ali**

*Faculty of Engineering / Electronics and Communication Department  
Zagazig University  
Zagazig, 44519, Egypt*

*hanahshaker@yahoo.com*

**M. I. Abdalla**

*Faculty of Engineering / Electronics and Communication Department  
Zagazig University  
Zagazig, 44519, Egypt*

*mabdalla2010@gmail.com*

---

## Abstract

In this paper, we propose an architecture framework for interworking of Long Term Evolution (LTE), Worldwide Interoperability for Microwave Access (WiMAX) and Wireless Local Area Network (WLAN) technologies. The aim is to offer users of various networks seamless high quality IP-based multimedia services access anywhere at any time. IP Multimedia Subsystem (IMS) is used in the proposed architecture for providing a platform through which telecommunications operators can merge the various networks. A Session Initiation Protocol (SIP) REFER method which provides uninterrupted service continuity is introduced. The proposed LTE-WiMAX and LTE-WLAN tight coupled interworking is compared with the UMTS-WiMAX and UMTS-WLAN tight coupled interworking. The two heterogeneous networks are simulated using OPNET Modeler 17.1. Various metrics are obtained to test the performance of the proposed technique. Results show that successful VoIP session handoffs with acceptable Quality of Services (QoS) levels can be performed. Results also show that the proposed architecture outperforms the previous architecture.

**Keywords:** IMS, LTE, WiMAX, WLAN, UMTS, SIP, EAP-AKA, Handoff, Heterogeneous.

---

## 1. INTRODUCTION

The evolving demand for mobile Internet and wireless multimedia applications has motivated the evolution of network infrastructure to a new one. The new approach will promise to revolutionize the services offered as peer-to-peer entities, which facilitate sharing. IP Multimedia Subsystem (IMS) represents that new approach. IMS is designed to provide robust multimedia services across roaming boundaries and over diverse access technologies [1]-[4].

The IMS will take communication to the next level by offering enriched communication means, since it is designed to provide robust multimedia services across roaming boundaries and over diverse access technologies. As the IMS networks use the Session Initiation Protocol (SIP) for session establishment, management and transformation, they are able to mix and match a variety of IP-based services in any way they choose during a single communication session and can add or drop services as and when they choose [2]. One of the key challenges in future network management is the guarantee of uninterrupted service continuity over dissimilar networks. To accomplish this continuity demand of mobile users roaming in wireless broadband networks, SIP REFER method is used [5], [6], [7].

In a previous work [8], we proposed a new heterogeneous network architecture that merges Long Term Evolution (LTE), Worldwide Interoperability for Microwave Access (WiMAX) and Wireless Local Area Network (WLAN) in an IMS compatible architecture. The proposed architecture incorporates a LTE core network, a WiMAX network and a WLAN network interconnected with the LTE core through specific functional entities and an IMS in charge of sessions' control. Thus, users can access the LTE Circuit-Switched (CS) based services through the WiMAX and WLAN networks, since they are authenticated in the Authentication, Authorization, and Accounting (AAA) Server and registered in the IMS core. The performance analysis of the proposed architecture was introduced with no mobility consideration.

In this paper, A SIP-based mobility management technique is proposed. When a user roams between different networks, this interworking affects the VoIP sessions and other services access. For uninterrupted service continuity, SIP REFER method is used to process handoff and provide successful mobility management. It follows a make-before-break handoff which prevents the destruction of the initial session if session handoff failed. OPNET modeler 17.1 is used for simulation. The custom task application is used to implement the newly developed SIP model, since OPNET's standard SIP component don't address the specification of the 3GPP's IMS. A custom mobility application is constructed and integrated to OPNET's existing LTE special module. The performance analysis of the proposed integration scheme is compared with IMS-based UMTS-WiMAX and UMTS-WLAN interworking architectures.

The rest of this paper is organized as follows: Section 2 discusses recent work related to IMS networks and the next generation heterogeneous networks. In Section 3, IMS subsystem is discussed in detail. Sections 4 and 5 present the UMTS-WiMAX, UMTS-WLAN and the proposed LTE-WiMAX, LTE-WLAN interworking architectures using IMS, respectively. Section 6 presents network modeling and the performance analysis before we conclude and present our future work in Section 7.

## **2. BACKGROUND AND RELATED WORK**

Since the IMS networks are still in an ongoing activity, the industry and the research community constantly try to face open issues and extend IMS beyond 3G, by proposing interworking architectures that aim on seamless service provisioning. An overview of IMS infrastructure along with its services, applications, and future potential is discussed by Esguevillas et al. in [3]. Munir and Gordon-Ross [4] analyzed in details the SIP-based IMS registration and session setup signaling delay for two novel interworking architectures to integrate WiMAX and third-generation (3G) networks . Munasinghe et al. investigated the behavior and management of a VoIP session for roaming users across network boundaries that incorporates SIP- REFER method in [5]. Angoma et al. proposed in [6] a real environment integrating architecture which guarantees the continuity of service during vertical handover between heterogeneous access networks technologies: WLAN, WiMAX and 3G. Nikolaos et al. [9] presented a complete signaling flow concerning the authorization, registration, session set up and vertical handoff processes, as well as, an analytic model for cost analysis of the proposed architecture. Munasinghe and Jamalipour [10] proposed architecture for interworking heterogeneous all-IP networks with an in-depth analysis of its performance. Vijayalakshmy and Sivaradje [11] presented QoS provisioning interworking model that integrates a WiMAX network, a UMTS network and a WLAN in an IMS compatible architecture and it is compared with WiMAX-UMTS interworking along with IMS. Chowdhury and Gregory [12] provided the results of a performance analysis of two potential 3G/WLAN integration schemes: tight and loose coupling. Mobile IP is used as a mobility management scheme and EAP-AKA for common authentication. Sharma and Leung[13] presented a lightweight, robust, and architecture compatible IMS authentication protocol that implements a one pass IMS procedure by promoting efficient key re-use for a mobile user. They derived an analytical model of the proposed scheme, and conduct numerical analysis that reveal a user authentication delay decrease of more than 50 percent. Then in [14], they presented a lightweight, robust, and architecture-compatible IMS authentication protocol that implements a one-pass IMS procedure by promoting efficient key reuse for a mobile user for LTE-femtocell heterogeneous access networks. Nithyanandan and Parthiban [15] achieved seamless vertical

handover in three interworking architectures that merge WLAN and WiMAX networks. El-Mohsen et al. in [16] evaluated VoIP performance parameters of two SIP handoff schemes used as a mobility management protocol between heterogeneous wireless networks. Rizvi et al. in [17] proved that the GGSN-WLAN integration performance is better than the SGSN-WLAN integration for all the applied applications and measurement parameters in UMTS-WLAN interworking architecture. In [18], Q. Duan and E. Lu described a technology to discover and select the network services that guarantee the QoS requirements of different networking applications.

### 3. THE IP MULTIMEDIA SUBSYSTEM (IMS)

IMS is a global, access-independent and standard-based IP connectivity and service control architecture that enables various types of multimedia services to end-users using common Internet-based protocols. Session Initiation Protocol (SIP) is a rendezvous protocol that is, a signaling protocol designed to establish, manage, and tear down multimedia sessions on the Internet. IMS uses SIP for session establishment, management, and transformation. In addition to the session control protocol there are a number of other protocols that play important roles in the IMS as Diameter, HTTP, etc. [1]-[4], [9], [11].

The IMS is a system architecture designed for supporting multimedia services for transmission over different access technologies. The IMS architecture is a collection of functions linked by standardized interfaces. Some of the IMS SIP entities are responsible for interfacing non-SIP IMS network nodes using different protocols designed for AAA. The IMS is 3-layer architecture. It consists of the Transport Layer, which includes all the entities for the supported access networks; the Control Layer where the core IMS network resides; whereas at the top exists the Service Layer which includes the application servers hosting the IMS services [1], [3], [4], [11].

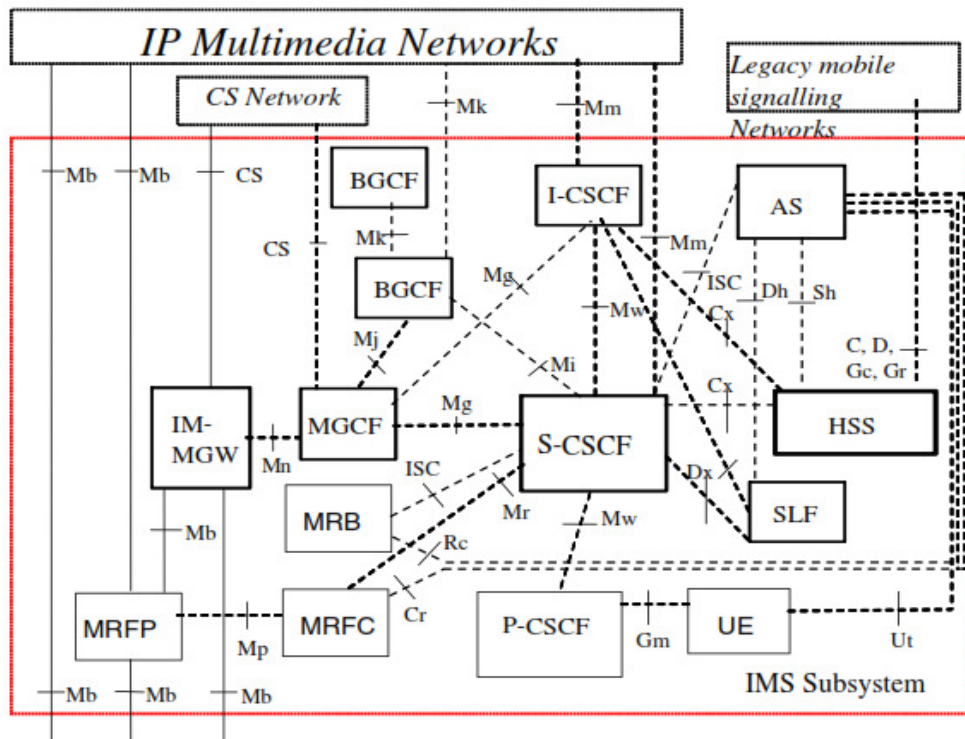

FIGURE 1: The Reference Architecture of the IP Core Network Subsystem.

### 3.1 IMS Components

The IMS core network, as shown in Figure. 1, predominantly consists of many nodes such as HSS (Home Subscriber Server), SLF (Subscriber Location Function), CSCF (Call/Session Control Function), P-CSCF (Proxy-CSCF), S-CSCF (Serving-CSCF), I-CSCF (Interrogating-CSCF), E-CSCF (Emergency-CSCF), IMS-MG (IMS-Media Gateway), etc. [1] - [4],[9].

### 3.2 IMS Registration and Session Initiation

IMS-level registration is the procedure which is used to authorize the user to access the IMS network and use the IMS services. It is done after IP connectivity for the signaling that has been gained from the access network and the application level registration can be initiated after the registration to the access is performed. IMS-level registration is accomplished by a SIP REGISTER request and the user is considered to be always roaming [1]-[4], [9], [19].

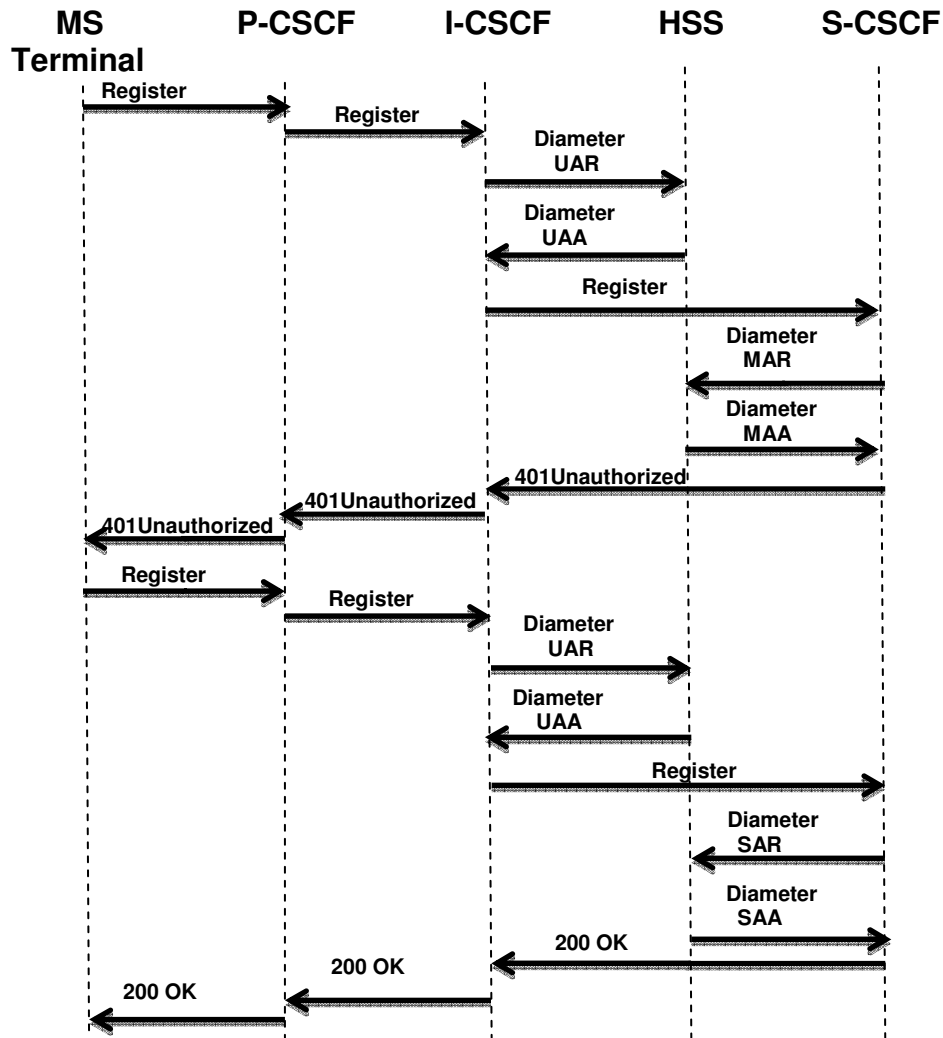

FIGURE 2: Registration at the IMS Level.

As shown in Figure. 2, The Mobile Station (MS) initiates the registration process by sending SIP register information flow to P-CSCF. Upon message reception, the P-CSCF examines the "home domain name" to discover the entry point to the home network as it might not reside to MS' home network. So the SIP "REGISTER" attaches to the information needed and sends the register information flow to the I-CSCF. To indicate whether the user is already registered and allowed, the Cx-Query/Cx-Select-Pull information flow should be sent to the HSS by the I-CSCF. A

Response is sent from the HSS to the I-CSCF and it will contain the S-CSCF name or a list of the qualifications of the available S-CSCFs. Using the name of the most appropriate S-CSCF; I-CSCF sends the register SIP “REGISTER” to S-CSCF. The S-CSCF contacts HSS to authenticate the MS. The HSS stores the S-CSCF name and the S-CSCF stores the information for the indicated user. A user invitation (“401Unauthorized”) is sent by the I-CSCF to the P-CSCF. The P-CSCF repeats the above presented messages exchange, with exception of the new “UAA” which this time contains routing information. The S-CSCF returns the 200 OK information flows. The I-CSCF shall release all registration information and The P-CSCF shall store the home network contact information, and shall send information flow to the MS.

When MS wants to have a session with another, it generates a SIP INVITE request and sends it to the P-CSCF which processes the request as in Figure. 3. The S-CSCF plays an important role in service provision as it is always located in the home network and services are always available to the user regardless of whether the user is roaming or not.

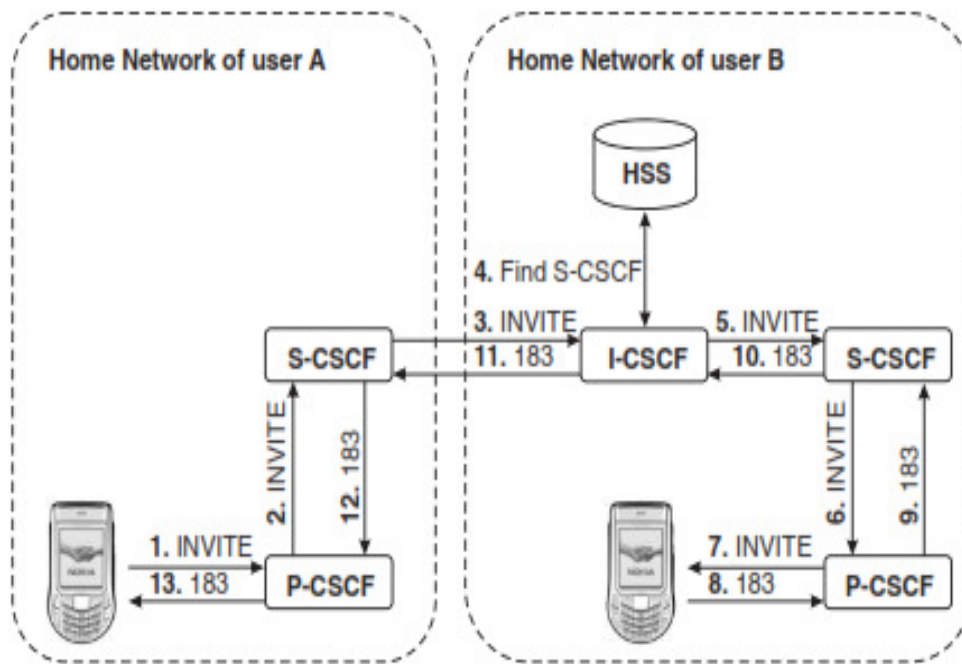
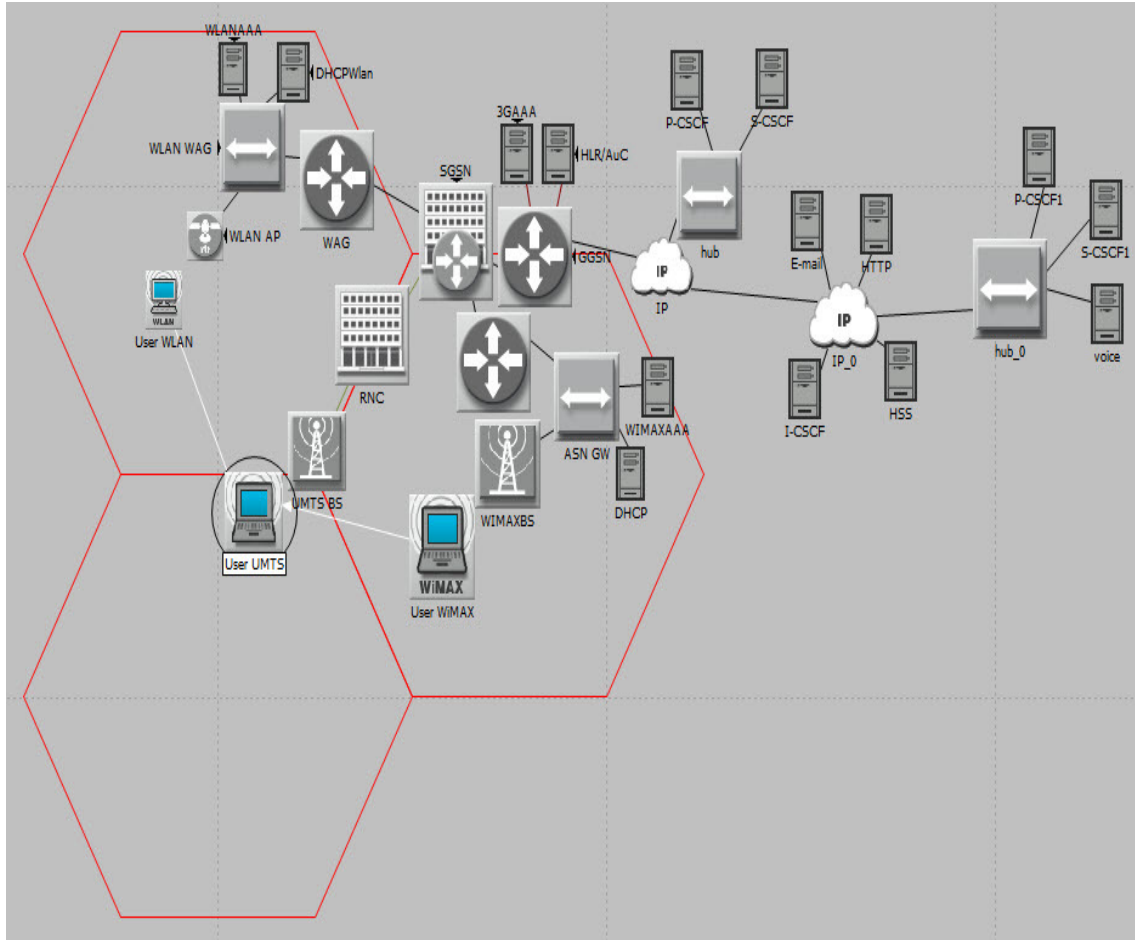

FIGURE 3: IMS Session Establishment Flow.

#### 4. UMTS-WiMAX AND UMTS-WLAN TIGHT COUPLED INTERNETWORKING ARCHITECTURES

The previous interworking models integrate UMTS-WiMAX network and UMTS-WLAN network using IMS compatible architecture. They incorporate a UMTS Core Network where the SGSN, the GGSN and the AAA Server reside, a WiMAX and a WLAN network interconnected with the UMTS Core through specific functional entities and an IMS in charge of sessions control.

As shown in Figure. 4, the tight coupling scheme connects WLAN WAG and WiMAX WG with the UMTS core network through Serving GPRS support node (SGSN). The flow of data originates from the WLAN or WiMAX users, goes through the SGSN and the GGSN 3G core network, before reaching the destination network.

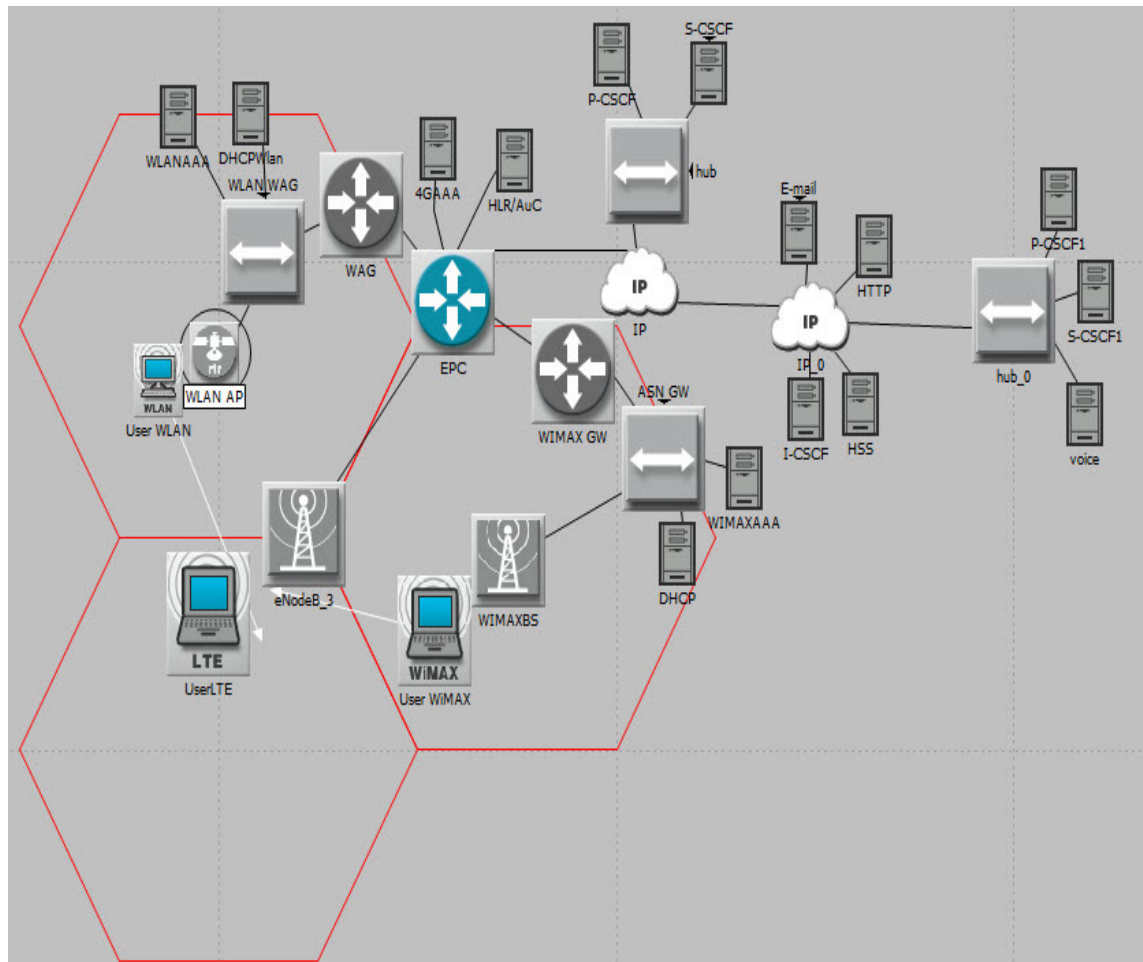

**FIGURE 4:** UMTS-WiMAX and UMTS-WLAN Interworking Architecture.

## 5. PROPOSED LTE-WiMAX AND LTE-WLAN TIGHT COUPLED INTERWORKING ARCHITECTURE

Our proposed framework architecture, as in Figure. 5, merges LTE-WiMAX network and LTE-WLAN network in an IMS compatible architecture. Our primary focus is to merge WLAN network or WiMAX network with a LTE network and to manage sessions by placing an IMS core on top of technologies. The flow of data originates from the source MS, through the EPC of LTE network, and reaches the destination network. More specifically, EPC of LTE network is directly connected to the WiMAX-GW using 10Gbps\_Ethernet duplex link interface, and to WLAN WAG using DS3 interface with point to point for supporting high speed and multimedia traffic. Advanced Ethernet servers are used to implement missing blocks of core network as AAA, DHCP, HLR, CSCF, S-CSCF, P-CSCF and HSS. An IMS core network is connected to the Ethernet hub using 10Gbps\_Ethernet duplex interface on top of three technologies. During the exchange of SIP signaling, EPC act as a router by merely forwarding SIP messages.

In the proposed network architecture, each mobile node is equipped with multiple radio interfaces (LTE interface, WLAN interface) in LTE-WLAN network or (LTE interface, WiMAX interface) in LTE-WiMAX network, and a SIP-based handover mechanism is implemented to manage handoff on behalf of the user.



**FIGURE 5:** LTE-WiMAX and LTE-WLAN Interworking Architecture.

### 5.1 Core Registration

When MS wants to register to the IMS core through the LTE network, he must first activate a Packet Data Protocol context (PDP). A PDP context is a record that is saved in the EPC, and contains information about the user and about the active session. When the WiMAX or WLAN network is concerned, each user accessing the IMS or data services must be registered in the HLR of the LTE network. As a result, The WLAN and WiMAX users must implement authentication protocols as Extensible Authentication Protocol / Authentication and Key Agreement (EAP-AKA) and The Dynamic Host Configuration Protocol (DHCP) before they can access to the 4G Network.

EAP-AKA is an authentication protocol used by the 4G to provide access security for interworking architecture between WiMAX or WLAN and LTE. It is used to authenticate the user in the Authentication Authorization and Accounting server (4GAAA). EAP-AKA is based on AKA mechanism so the 4G home domain does not delegate responsibility for security and billing authentication to the underlying WLAN/WiMAX network [20], [21]. EAP-AKA procedures as in Figure. 6 use request/response message pair to support mutual authentication and to generate session keys.

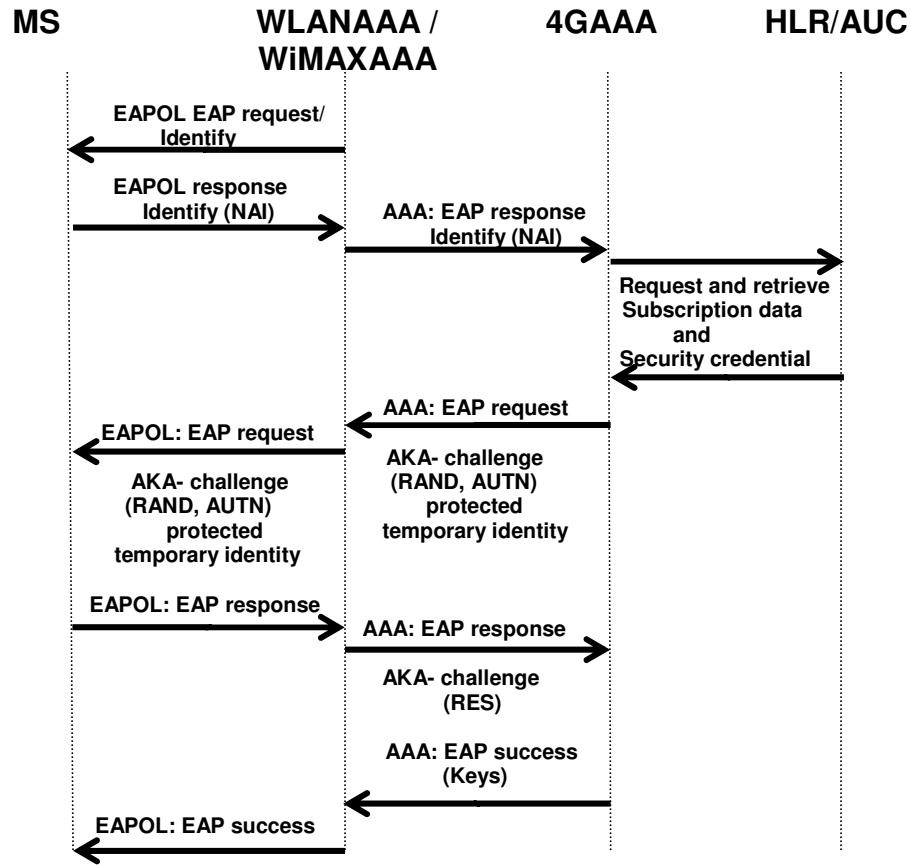

FIGURE 6: Authentication Based on EAP-AKA Scheme.

The Dynamic Host Configuration Protocol (DHCP) [22], as shown in Figure. 7, is a client-server model framework used to allocate network addresses and deliver IP configuration parameters to MS. MS initiates the procedure by sending “DHCP Discover” message to the DHCP server. The server responds using “DHCP Offer” message. MS sends back “DHCP Request” message to request IP configuration parameters. Finally, “DHCP Response” message is sent back by the server. After obtaining his IP configuration, MS will be able to exchange packets with any other host in the Internet.

Then, all users (LTE/WiMAX/WLAN) can register to the IMS core through the LTE network core using IMS-level registration procedures as mentioned in section 3.

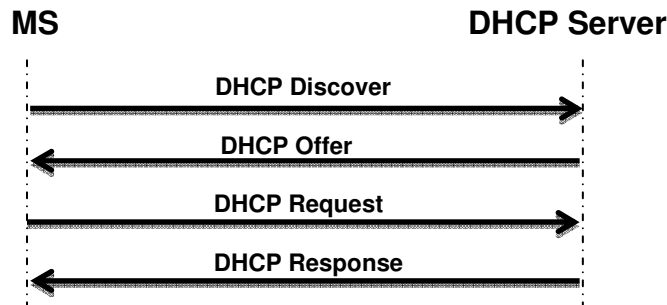

FIGURE 7: DHCP Scheme.



### 5.2 Proposed SIP REFER Handover Mechanism

When the MS roams to another network, he searches for availability of access networks, decides and starts executing vertical handover. The need for a vertical handoff mechanism arises for handing off an ongoing VoIP session to another network. In order to ensure seamless continuity of services, the SIP REFER method is used to provide both terminal and session mobility. OPNET Modeler 17.1 is used to construct a SIP-IMS network model for validating the interworking of the presented architecture. Since OPNET's standard SIP components do not address the specifications of the 3GPP's IMS, substantial modifications are required. The custom task application is used to implement the newly developed SIP-IMS model and the dual mode mobile node. A custom mobility application which consists of the EAP-AKA authentication, DHCP registration, IMS Registration, session establishment and SIP-based handover messages mechanism is constructed and integrated to OPNET's existing LTE Special Module. The modification and additional nodes required for the proposed architecture are shown in Figure. 5.

Figure. 8 illustrates the SIP REFER protocol applied to perform handover in the proposed architecture. First, the MS interface I performs authentication procedures to access its network. Then, The MS executes the basic session handoff process steps. The new session flow can be initiated after this process is successfully done. It is important to note that until such time, the other interface remains active for the data flow.

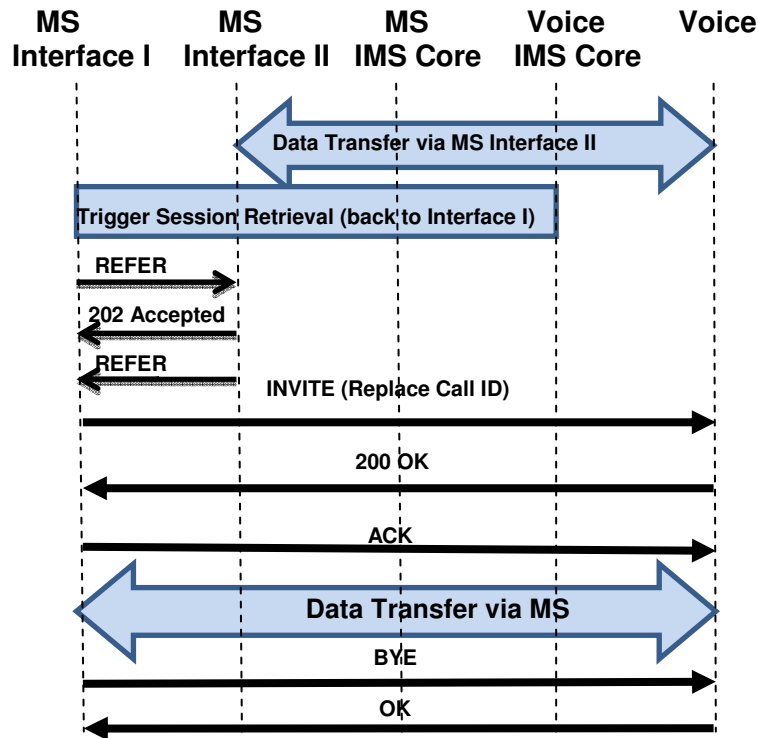

FIGURE 8: SIP REFER Handover Mechanism.

Simulation time is assumed to be 700 seconds for the VoIP application. G.711 VOIP codec with data rate of 64 kb/s is used. Email and WEB browsing activities are implemented as the background traffics. MS switches to a different network each time he performs a handoff. The SIP handoff procedures occur after switching between interfaces of the mobile node using the Routing Information Protocol (RIP). The Transitional Time is considered to be 6 seconds. The Processing Delay and Diameter Delay are considered to be 0.0001 seconds and 0.005 seconds respectively.

## 6. PERFORMANCE ANALYSIS

To test the performance of the proposed architecture, performance metrics are obtained. These metrics are: task response time, traffic sent and traffic received, jitter, packet end to-end delay. Also, a comparison between the proposed tight coupled architecture and the previous tight coupled networks is presented.

In the following two subsections, the results are estimated in case of a MS handoff between WLAN network and LTE network and between WiMAX network and LTE network, respectively. The results are compared with the previous WLAN-UMTS and WiMAX-UMTS networks.

### 6.1 LTE-WLAN Internetworking

#### 6.1.1 Task Delay Time

Table 1 records the time taken by each interface to perform the IMS session establishment and SIP Handover tasks in LTE-WLAN and UMTS-WLAN architectures.

Task	MS Movement			
	LTE to WLAN	UMTS to WLAN	WLAN To LTE	WLAN To UMTS
IMS session establishment	0.02944	0.02897	0.142	4.226738
SIP Handover	0.05793	0.05559	0.075	1.110001

TABLE 1: Task Delay Time (seconds).

From table 1, it is noticed that total delay time taken by a user to handoff in LTE-WLAN interworking architecture is lower than total time taken by a user in UMTS-WLAN interworking architecture.. It is apparent that switching to UMTS interface takes higher time than switching to LTE interface.

#### 6.1.2 Voice Traffic

As shown in Figure. 9, it is noted that the voice traffic sent and received decrease as the number of handoffs increases. We also notice that the packet loss in the proposed LTE-WLAN architecture is much lower than the UMTS- WLAN architecture.

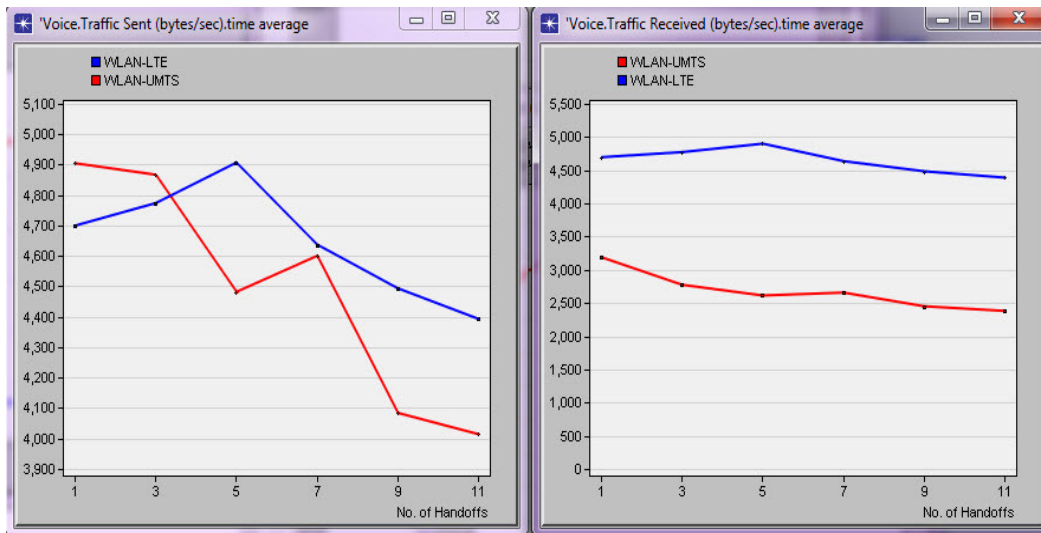

(a) Traffic Sent.

(b) Traffic Received.

FIGURE 9: Voice Traffic vs. Number of Handoffs.

### 6.1.3 Voice Jitter and Voice Packet End to End Delay

Voice Jitter is defined as a variation in the delay of received voice packets. As shown in Figure. 10(a), our proposed coupled architecture has approximately no delay in the received voice packet. Voice end to end delay represents the variation in the end to end delays for voice packets. From Figure. 10(b), the delay variation of the LTE-WLAN coupled architecture is lower than UMTS-WLAN coupled architecture along the simulation time.

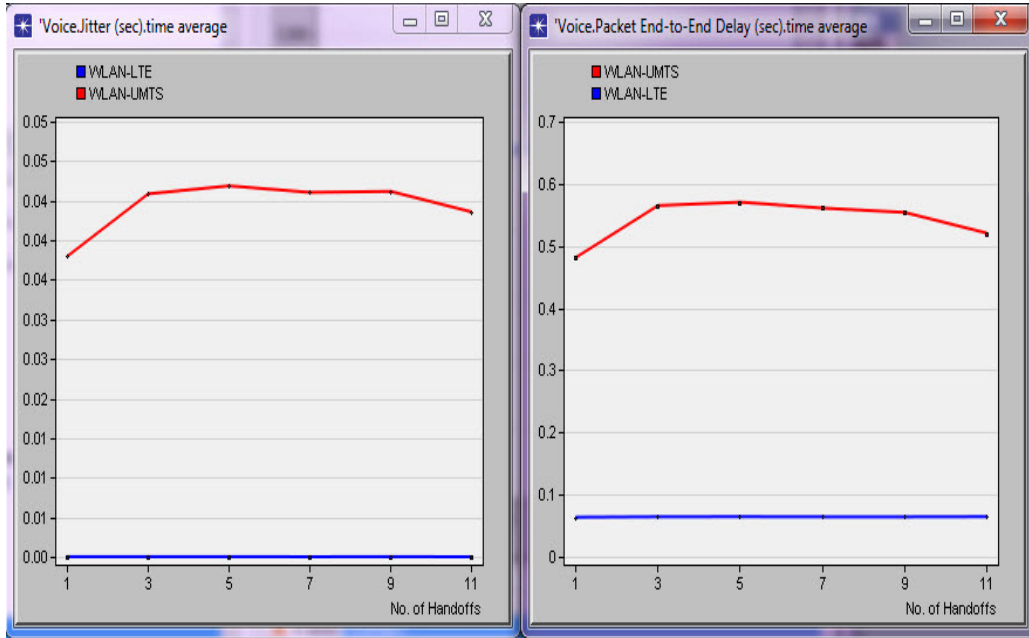

(a) Voice Jitter.

(b) Voice Packet end to end Delay.

FIGURE 10: Voice jitter and packet end to end delay (sec) during vertical handoff.

## 6.2 LTE-WiMAX Internetworking

### 6.2.1 Task Response Time

Task	MS Movement			
	LTE to WiMAX	UMTS to WiMAX	WiMAX To LTE	WiMAX To UMTS
IMS session establishment	0.374395	0.3444	0.142	4.226738
SIP Handover	0.165605	0.1006	0.075	1.110001

TABLE 2: Task Delay Time (seconds).

Table 2 records the task delay times in LTE-WiMAX and UMTS-WiMAX architectures. It is noticed that the time taken by a user to perform SIP-handover in LTE-WiMAX interworking architecture is lower than the total delay taken by a user in UMTS- WiMAX interworking architecture.

### 6.2.2 Voice Traffic

Comparing Figure. 11(a) and Figure. 11(b) for voice traffic sent and received, it is noted that the packet loss in the proposed LTE- WiMAX architecture is much lower than the UMTS- WiMAX architecture.

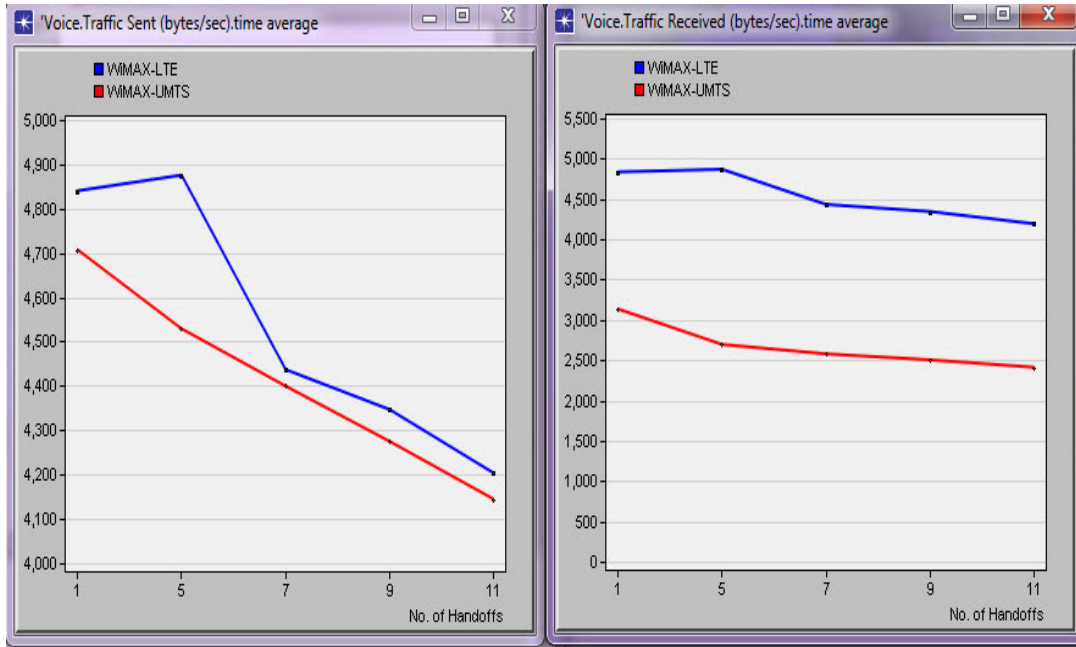

(a) Traffic Sent.

(b) Traffic Received.

FIGURE 11: Voice Traffic vs. Number of Handoffs.

### 6.2.3 Voice Jitter and Voice Packet End to End Delay

As shown in Figure. 12(a), voice jitter in our proposed coupled architecture is approximately zero. From Figure. 12(b), the voice end to end delay of the LTE-WiMAX coupled architecture is lower than UMTS-WiMAX coupled architecture.

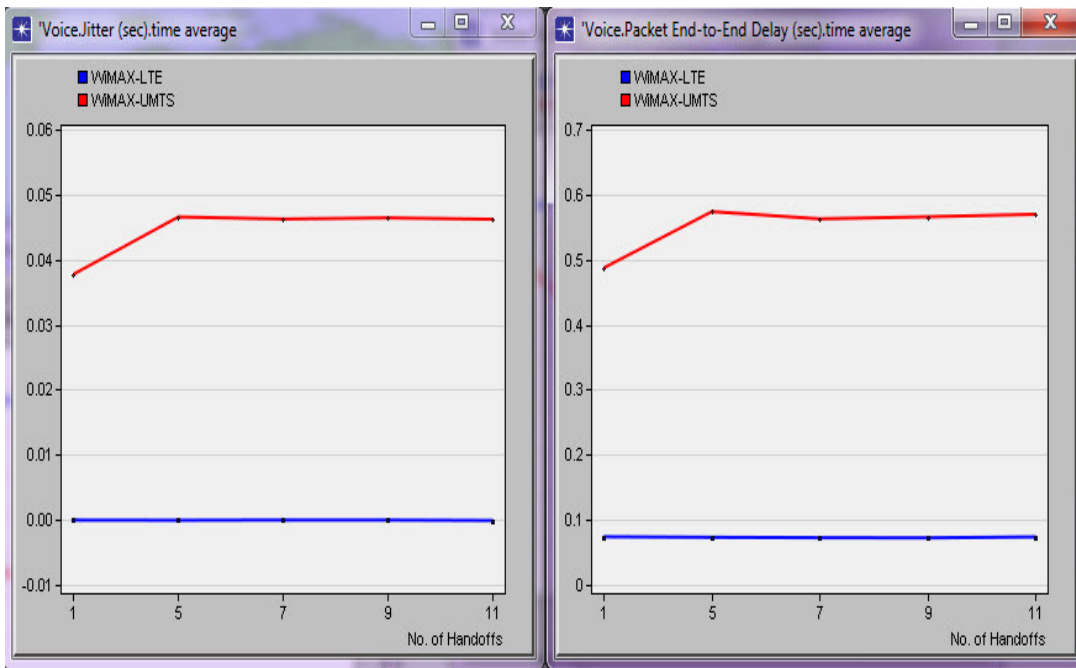

(a) Voice Jitter.

(b) Voice Packet end to end Delay.

FIGURE 12: Voice jitter and packet end to end delay (sec) during vertical handoff.

Comparing our results with the previous proposed architectures and algorithms in [4], [5], [9]-[12], [15]-[17], the proposed architecture has the advantages of upgrading to the 4G (LTE) which provides higher data rate and less authentication time. Moreover, the proposed architecture uses IMS which is a standardized next generation network that can incorporate a variety of wireless and wire line technological alternatives for users to access the global telecommunication network. Using SIP REFER method in the proposed network provides seamless data services with QoS negotiation for IP multimedia sessions during handoff process to provide successful mobility management. It also prevents the destruction of the initial session if session handoff failed as it follows a make-before-break handoff.

## 7. CONCLUSIONS AND FUTURE WORK

In this paper, we introduce an architecture framework for integrating LTE, WiMAX and WLAN for seamless service provisioning. We propose a handover procedure which promises uninterrupted service continuity during the switching between different networks. Seamless real-time multimedia services during handoff between two access networks are achieved by SIP REFER method which follows a make-before-break handoff, thus preventing the destruction of the initial session. Using OPNET Modeler 17.1, the results show that the proposed architecture gives high performance for each user during data transfer and shows the capability of performing successful VoIP session handoffs between dissimilar networks whilst maintaining acceptable QoS levels.

Since IMS networks are still in a development stage, we will try in the future to solve open issues concerning session control, authorization, charging, personal mobility, etc. The main motivation for our future work is towards reducing the packet losses during vertical handover between different access networks by applying different mobility management techniques. The aim is to achieve seamless mobility support which is considered one of the most critical research issues to provide uninterrupted wireless services to mobile users in such a heterogeneous network environments.

## 8. ACKNOWLEDGMENT

The authors would like to thank Egyptian National Telecommunication Regulatory Authority (NTRA) and Prof. Fadel Digham (R&D Director at NTRA, Egypt) for providing license to use OPNET17.1 general wireless module.

## 9. REFERENCES

- [1] M. Poikselka and G. Mayer, *The IMS IP Multimedia Concepts and Services*, 3rd ed., United Kingdom: Wiley, 2009.
- [2] G. Camarillo and M.A.G. Martin, *The 3G IP Multimedia Subsystem (IMS)*, 3rd ed., United Kingdom: Wiley, 2008.
- [3] A. Sanchez-Esguevillas et al., "IMS: The new generation of internet-protocol-based multimedia services," *Proceedings of the IEEE*, vol. 101, pp. 1860 – 1881, Aug. 2013.
- [4] A. Munir and A. Gordon-Ross, "SIP-Based IMS signaling analysis for WiMAX-3G interworking architectures," *IEEE Transactions on Mobile Computing*, vol. 9, pp. 733 - 750, May 2010.
- [5] K.S. Munasinghe, M.R. Kibria and A. Jamalipour, "Designing VoIP session management over interworked WLAN-3G networks," *IEEE Wireless Communications*, vol. 15, pp. 86 - 94, Aug. 2008.
- [6] B. Angoma, M. Erradi, Y. Benkaouz, A. Berqia and M.C. Akalay, "HaVe-2W3G: A vertical handoff solution between WLAN, WiMAX and 3G networks," in *Proc. IWCMC*, 2011, pp. 101-106.

- [7] R. Sparks, "The Session Initiation Protocol (SIP) Refer Method," IETF RFC No.3515, 2003.
- [8] R.A. Hamada, H.S. Ali and M. Abdalla, "Performance evaluation of a novel IMS-based architecture for LTE-WiMAX-WLAN interworking," accepted at 2<sup>nd</sup> Int. Conf. on Engineering and Technology ICET, Cairo, Egypt, 2014
- [9] P. Nikolaos, S. Aggeliki and D.D. Vergados, "An IMS-based network architecture for WiMAX-UMTS and WiMAX-WLAN interworking," Elsevier Computer Communications, vol. 34, pp. 1077–1099, June 2011.
- [10] K.S. Munasinghe and A. Jamalipour, "Interworked WiMAX- 3G cellular data networks: an architecture for mobility management and performance evaluation," IEEE Transactions on Wireless Communications, vol. 8, pp. 1847 - 1853, April 2009.
- [11] G. Vijayalakshmy and G. Sivaradje, "A QoS guaranteed tight coupled WiMAX-3G-WLAN convergence using IMS signaling analysis," in Proc. ICCI, 2013, pp. 1-8.
- [12] A. Chowdhury and M.A. Gregory, "Hybrid next generation mobile system analysis based on internet applications," in Proc. ATNAC, 2010.
- [13] M.J. Sharma and V.C.M. Leung, "Improved IP multimedia subsystem authentication mechanism for 3G-WLAN networks," in Proc. INFOCOM WKSHPs, 2011.
- [14] M.J. Sharma and V.C.M. Leung, "IP Multimedia subsystem authentication protocol in LTE-heterogeneous networks," SpringerOpen Human-centric Computing and Information Sciences, vol. 2, pp. 2-16, Oct. 2012.
- [15] L. Nithyanandan and I. Parthiban, "Seamless vertical handoff in heterogeneous networks using IMS technology," in Proc. ICCSP, 2012, pp. 32-35.
- [16] O.A. El-Mohsen, H.A.M. Saleh and S. Elramly, "SIP-Based handoff scheme in next generation wireless networks," in Proc. NGMAST, 2012, pp. 131-136.
- [17] S. Rizvi et al., "Tight coupling internetworking between UMTS and WLAN: challenges, design architectures and simulation analysis," International Journal of Computer Networks," vol. 3, pp. 116-134, May 2011.
- [18] Q. Duan and E. Lu, "Network service description and discovery for the next generation internet," International Journal of Computer Networks, vol. 1, pp. 46-65, Nov. 2009.
- [19] 3GPP, 2013, IP Multimedia Subsystem (IMS), 3GPP TS 23.228.
- [20] J. Arkko and H. Haverinen, "EAP-AKA Authentication," IETF RFC 4187, Jan. 2006.
- [21] 3GPP, 2012, 3GPP System to Wireless Local Area Network (WLAN) Interworking; System Description, 3GPP TS 23.234.
- [22] R. Droms, "Dynamic Host Configuration Protocol," IETF RFC No.2131, March 1997.

## INSTRUCTIONS TO CONTRIBUTORS

The International Journal of Computer Networks (IJCN) is an archival, bimonthly journal committed to the timely publications of peer-reviewed and original papers that advance the state-of-the-art and practical applications of computer networks. It provides a publication vehicle for complete coverage of all topics of interest to network professionals and brings to its readers the latest and most important findings in computer networks.

To build its International reputation, we are disseminating the publication information through Google Books, Google Scholar, Directory of Open Access Journals (DOAJ), Open J Gate, ScientificCommons, Docstoc and many more. Our International Editors are working on establishing ISI listing and a good impact factor for IJCN.

The initial efforts helped to shape the editorial policy and to sharpen the focus of the journal. Started with Volume 6, 2014, IJCN aims to appear with more focused issues. Besides normal publications, IJCN intend to organized special issues on more focused topics. Each special issue will have a designated editor (editors) – either member of the editorial board or another recognized specialist in the respective field.

We are open to contributions, proposals for any topic as well as for editors and reviewers. We understand that it is through the effort of volunteers that CSC Journals continues to grow and flourish.

### IJCN LIST OF TOPICS

The realm of International Journal of Computer Networks (IJCN) extends, but not limited, to the following:

- Algorithms, Systems and Applications
- ATM Networks
- Cellular Networks
- Congestion and Flow Control
- Delay Tolerant Networks
- Information Theory
- Metropolitan Area Networks
- Mobile Computing
- Multicast and Broadcast Networks
- Network Architectures and Protocols
- Network Modeling and Performance Analysis
- Network Security and Privacy
- Optical Networks
- Personal Area Networks
- Telecommunication Networks
- Ubiquitous Computing
- Wide Area Networks
- Wireless Mesh Networks
- Ad-hoc Wireless Networks
- Body Sensor Networks
- Cognitive Radio Networks
- Cooperative Networks
- Fault Tolerant Networks
- Local Area Networks
- MIMO Networks
- Mobile Satellite Networks
- Multimedia Networks
- Network Coding
- Network Operation and Management
- Network Services and Applications
- Peer-to-Peer Networks
- Switching and Routing
- Trust Worth Computing
- Web-based Services
- Wireless Local Area Networks
- Wireless Sensor Networks

## **CALL FOR PAPERS**

**Volume: 6 - Issue: 3**

**i. Submission Deadline :** May 15, 2014      **ii. Author Notification:** June 10, 2014

**iii. Issue Publication:** June 2014



## **CONTACT INFORMATION**

### **Computer Science Journals Sdn Bhd**

B-5-8 Plaza Mont Kiara, Mont Kiara

50480, Kuala Lumpur, MALAYSIA

Phone: 006 03 6207 1607

006 03 2782 6991

Fax: 006 03 6207 1697

Email: [cscpress@cscjournals.org](mailto:cscpress@cscjournals.org)

CSC PUBLISHERS © 2014  
COMPUTER SCIENCE JOURNALS SDN BHD  
B-5-8 PLAZA MONT KIARA  
MONT KIARA  
50480, KUALA LUMPUR  
MALAYSIA

PHONE: 006 03 6207 1607  
006 03 2782 6991

FAX: 006 03 6207 1697  
EMAIL: [cscpress@cscjournals.org](mailto:cscpress@cscjournals.org)